

# DH Series Hydraulic Dock Leveler

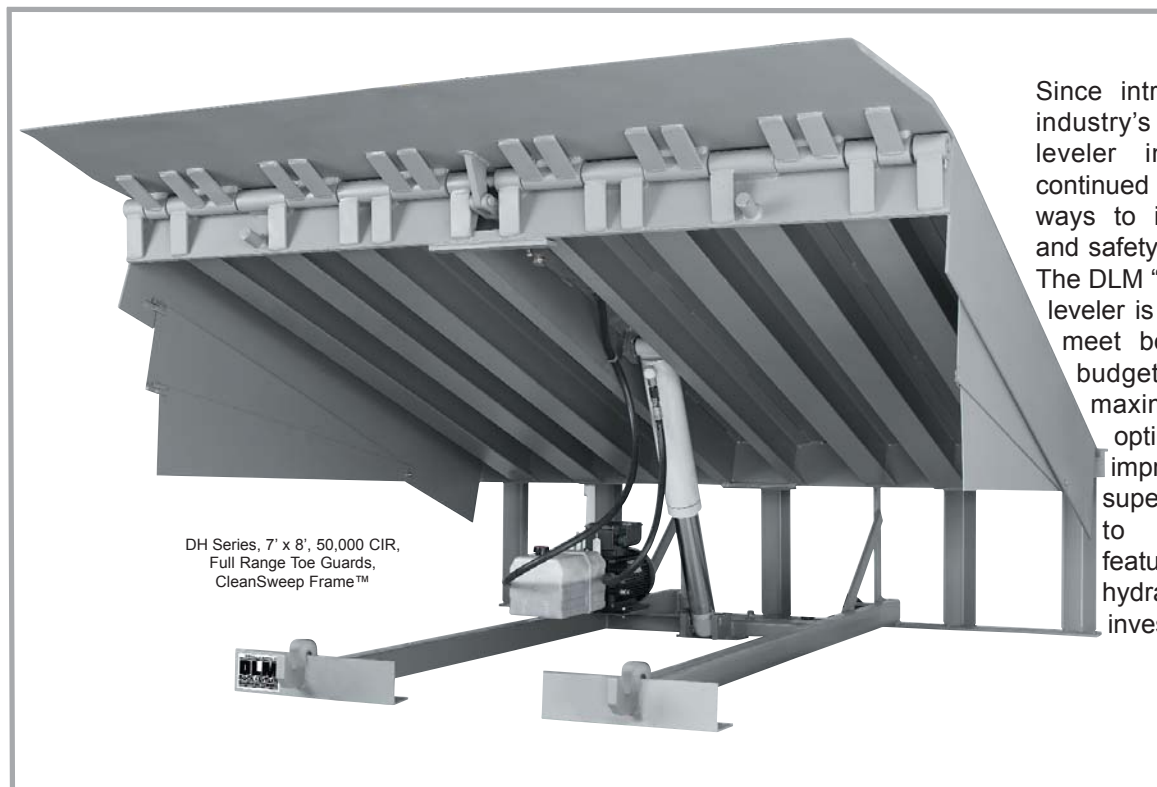

DH Series, 7' x 8', 50,000 CIR,  
Full Range Toe Guards,  
CleanSweep Frame™

Since introducing the freight industry's first Edge-of-Dock leveler in 1962, DLM has continued to provide innovative ways to improve productivity and safety at the loading dock. The DLM "DH" Series hydraulic leveler is value engineered to meet both application and budget constraints while maximizing productivity, optimizing efficiency and improving safety. From superior structural design to unlimited operator features, the "DH" Series hydraulic leveler is a wise investment.

## DLM Overview

- Industry Experience Since 1962
- Privately Held - Customer Focused Enterprise
- Extensive Application Experience
- Fully Integrated Manufacturing Facilities
- On-Site Engineering & Customer Support
- National Network of Knowledgeable Sales and Service Representatives
- Superior Structural Construction
- Accepted Nationally by Fortune 500 Companies

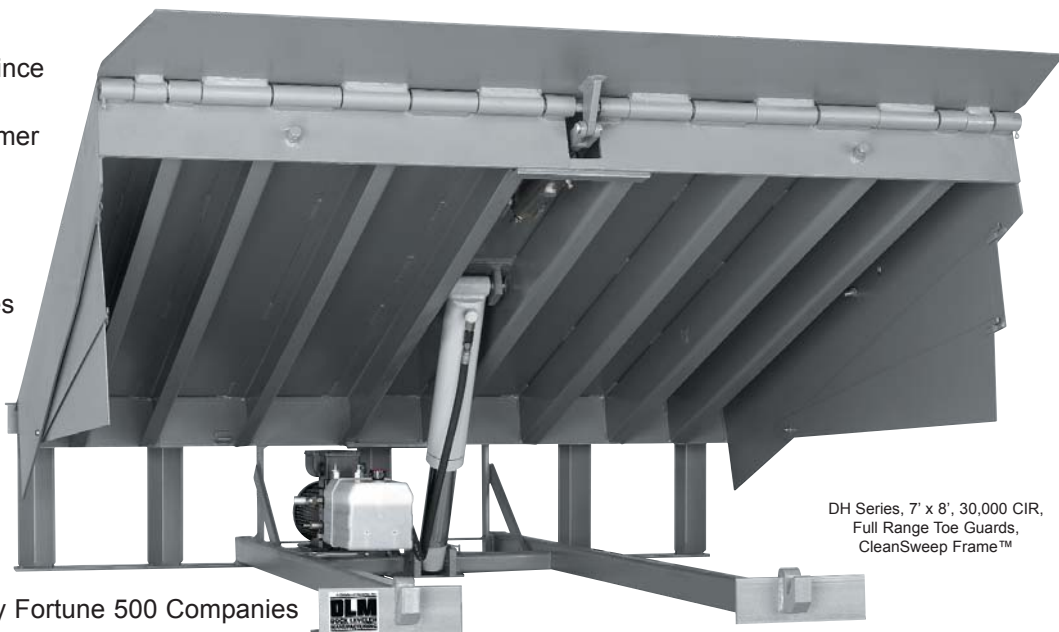

DH Series, 7' x 8', 30,000 CIR,  
Full Range Toe Guards,  
CleanSweep Frame™

# DH Series Hydraulic Dock Leveler



DLM's continuing commitment, is to design and build the very best dock levelers our industry has to offer. A strong customer focus has facilitated the inclusion of important user features into every "DH" Series leveler - important features like:

## Structurally Superior

- Over 29" of direct rear hinge support - heaviest in the industry.
- Four sided box construction provides unmatched structural integrity.
- Deck construction is capacity dependent to insure your loading bridge matches the demands of the facility.
- Leveler lip and deck are constructed with high-strength 55,000 lb yield, safety treadplate.
- Deck support members are application dependent
  - Low Capacity - Roll form "C" channel
  - Medium Capacity - Structural "C" channel
  - Heavy Capacity - Structural "C" channel and "I" beam
- Close and consistent spacing of beams provide necessary support for 3-wheeled and 4-wheeled fork trucks.

## Simple Push Button Control

- Non-metallic Nema 4 single push button control.
- Control components are UL listed or recognized.
- Overload protection for motor is standard.
- Optional interlocking and integrated panels are available.

## DH Series Standard Features Include ...

- |   |                                     |
|---|-------------------------------------|
| • Simple Push Button Control                  | • Night Locks/Cross Traffic Support |
| • Four Sided Box Construction - Deck Assembly | • Motor Overload Protection         |
| • Inverted Single Acting Hoist Cylinder       | • Low Maintenance Design            |
| • Full Hydraulic Lip Activation               | • Full Range Toe Guards             |
| • Velocity Safety Stop                        | • Two (2) B410-14 Laminated Bumpers |
| • Lockout/Tagout Maintenance Strut            |                                     |

## Efficient Power Source

- 1.5 HP totally enclosed fan cooled (TEFC) motor.
- 115v single phase (3 phase optional).
- Translucent tank, fast fluid level inspection.
- Elevated frame mounted design keeps clear of debris.
- Integral cartridge valve is built into pump.



## Heavy Duty Single Acting Main Cylinder

- Inverted cylinder mount keeps hose routing protected under deck.
- Chrome plated 3½" rod with 3" ID bore adds stability during ramp hoist and "Lock-Up" conditions.
- Externally mounted non-adjustable, velocity safety fuse prevents free fall of loaded platform to 3".



## Positive Lip Extension

- Nickel plated lip cylinder for added corrosion protection.
- Fully yieldable design to protect mechanism from backing truck.
- Cushioned lip fall.

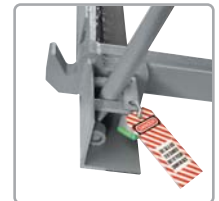

## CleanSweep™ Frame

- Provides clear access to area beneath platform.
- Allows easy removal of debris.
- Ideal where maintaining sanitary standards is important.

## Lockout/Tagout Maintenance Struts

- Permanently mounted, hinged maintenance strut supports deck during maintenance or inspection.
- Hinged maintenance strut lockout/tagout capable.

**Designed, Engineered & Manufactured  
in the U.S.A.**

**Distributed By:**

 Fray Pedro de Gante 85, Cimataro, Santiago de Querétaro, Querétaro, México CP 76030

 (442) 727-0441

 contacto@klh.com.mx

**klh** de México  
[www.klh.com.mx](http://www.klh.com.mx)